

JVC®

The Perfect Experience / —
/

1/3" CCD COLOUR VIDEO CAMERA

TK-C9300E

(24VAC/12VDC)

TK-C9301EG

(220-240VAC)



SuperLoLux™

COLOUR IN VIRTUAL ZERO LUX



580 TV Lines
True Day/Night

Lens not included



■ High-Resolution of 580 TV Lines

Newly developed 14 bit DSP enables industry-leading high quality pictures

■ Super LoLux™ Sensitivity

0.05 lx at colour mode (50% video level, F1.2, AGC HIGH)
0.006 lx at B&W mode (50% video level, F1.2, AGC HIGH)

■ Industry-leading S/N Ratio of 52dB

■ ExDR Plus – Advanced Wide Dynamic Range

JVC-original technology to reproduce clearer images for both bright and dark areas

■ 3D Noise Reduction

Powerful system to reduce noise in dark environments

■ Up to 128x of Slow Shutter

Increases visibility even in low light situations

■ Area White Balance

New function that can apply Auto White Balance to a specific area

■ Black Level Adjustment

Intelligent adjustment for dark areas to provide images without black out

■ Easy Installation with Well-Conceived Menu

Combination of DIP switch and built-in Menu makes detailed settings simple and easy

■ Variety of Functions for Precise Monitoring

- Automatic Gain Control (AGC)
- 4 Area Patterns for Backlight Compensation (BLC)
- Manual and Auto Tracking White Balance
- 1.4x/2.0x Digital Zoom
- Privacy Mask for protecting against intrusive monitoring
- Display Mode Selection for CRT and LCD
- AUX Terminal
- CCD White Spot Compensation
- Focus Adjustment Mode for accurate focusing
- 24VAC/12VDC Dual Voltage (TK-C9300E) or 220V-240VAC (TK-C9301EG) selectable

■ Eco-Friendly Super Low Power Consumption

Approx. 40% lower than conventional models



Reliable Day & Night Surveillance with High-Resolution Images and Precise Colour Reproduction

Super LoLux™ "COLOUR IN VIRTUAL ZERO LUX"

This camera has been designed to assure precise colour reproduction in low light situations. It is possible to identify image colours in much darker places.



Normal camera



JVC Super LoLux™

ExDR Plus

ExDR (Extended Dynamic Range) Plus function is able to clearly display people and characters in the foreground even when they're up against an extremely brightly lit background. And to make the dark parts of the image more clearly visible, it combines Dual Shutter with AGC function to achieve optimal image quality throughout the entire picture.



Normal image



ExDR Plus

3D Noise Reduction (3DNR)

3DNR is the powerful method to improve image quality even though it's shot in the dark. Noise data is detected by comparing some continuous frames and reduced by blending it into other frames over time.



Normal



3DNR

Area White Balance

Auto White Balance can be applied to a designated area. With this, colour casting can be prevented by setting the white balance within an area while avoiding strong colour zones.

Specifications

TK-C9300E/TK-C9301EG

Signal system	PAL
Image device	1/3 type IT CCD
Number of effective pixels	440,000 (752H x 582V)
Sync system	Internal
Scanning system	2:1 interlace, 625 lines
Scanning frequency	15.625kHz (H), 50Hz (V)
Video output	Composite video signal: 1.0V (p-p), 75 ohms (BNC)
Video S/N ratio	52 dB (AGC off)
Horizontal resolution	580 TV lines
Minimum illumination (typical)	0.05 lx (50%, F1.2, AGC HIGH) 0.025 lx (25%, F1.2, AGC HIGH)
B&W mode	0.006 lx (50%, F1.2, AGC HIGH) 0.003 lx (25%, F1.2, AGC HIGH)
Iris control	DC iris
White balance	ATW (wide/narrow) / AWC / Manual (ATW colour temp. range 2300K to 10,000K)
Day/Night	True D/N with IR cutoff filter
Wide dynamic range function	ExDR Plus (by dual shutter)
3DNR	NORMAL / HIGH
Display mode (Monitor type)	LCD1/LCD2/CRT
BLC	off/on (4 patterns)
AGC	OFF/MID/HIGH
Sens-up	off / x2 to x128
Digital zoom	x1, x1.4, x2
Motion detect	off/on
Privacy mask	4 areas
Focus adjustment mode	Yes
Lens mount	CS
AUX (Alarm terminal)	1
Power supply	TK-C9300E: 24VAC (50Hz/60Hz) / 12VDC TK-C9301EG: 220-240VAC (50Hz/60Hz)
Power consumption	TK-C9300E: 220 mA TK-C9301EG: 40 mA
Operating temperature range	-10°C to 50°C (0°C to 40°C recommended)
Dimensions (WxHxD)	55mm x 61mm x 126mm
Weight (approx.)	TK-C9300E: 270g TK-C9301EG: 470g

Dimensions

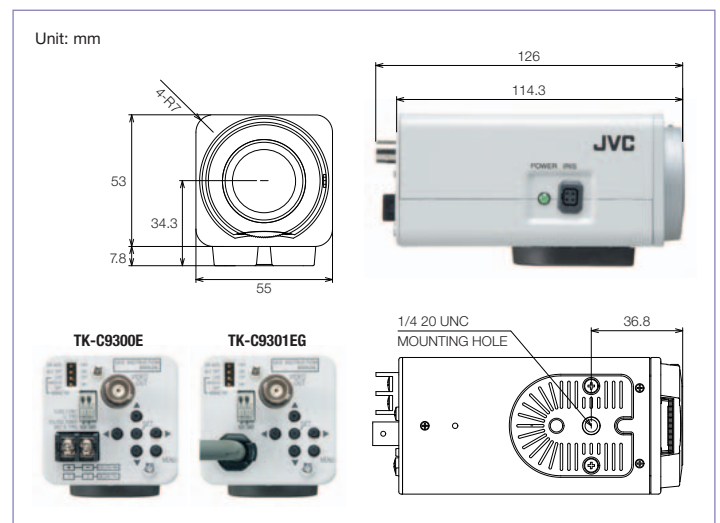

Note: Screen images are explanatory purpose and not actual images attained using this product. All brand or product names may be trademarks and/or registered trademarks of their respective owners. Copyright © 2009, Victor Company of Japan, Limited. All Rights Reserved.

JVC®

DISTRIBUTED BY

Design and specifications subject to change without notice.



■ Hachioji Business Centre of Victor Company of Japan, Ltd. has received ISO14001 Certification for environmental management and ISO9001 Certification for quality assurance management.

Printed in Japan
KCN-1855B TK-C9300E/C9301EG 2009/9
"JVC" is the trademark or registered trademark of Victor Company of Japan, Limited.